

INGRAM

COMPACTION, LLC

RP915B

Pneumatic Tired Roller
Rigid Frame • 9 Pneumatic Tires • 15 Tons

Features:

80 hp Cummins diesel engine.

Speed 0-16 mph.

All wheel oscillation allows uniform compaction on uneven surfaces.

Electronic Displacement Control (EDC) propel.

Side-to-side seat slide with 180° rotation.



(Shown with optional equipment)

HELPING BUILD AMERICA'S ROADS SINCE 1909

INGRAM

RP915B

Weights:

Empty	12,500 lbs.
Water	21,800 lbs.
Dry sand	27,500 lbs.
Wet sand	(Maximum ballast) 30,500 lbs.

Loads Per Tire:

Empty	1,389 lbs.
Water	2,422 lbs.
Dry sand	3,055 lbs.
Wet sand	3,389 lbs.

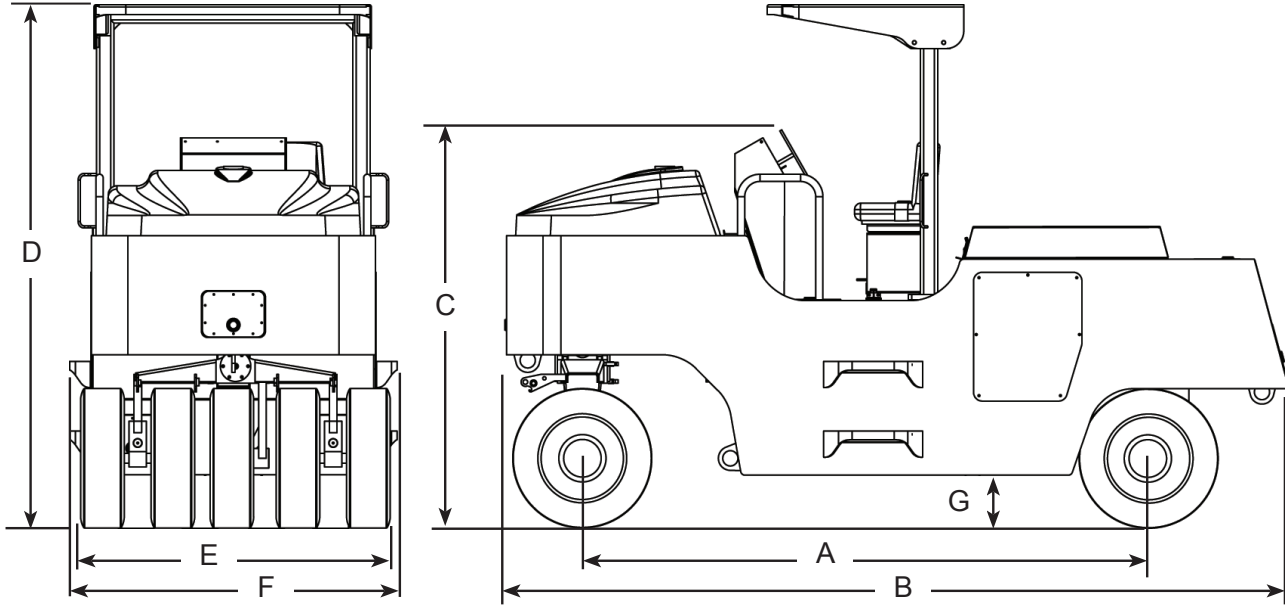

DIMENSIONS:

A. Wheelbase	130.5"	F. Overall width	75.4"
B. Overall length	180.0"	G. Ground clearance	11.0"
C. Overall Height	94.0"	Outside turning radius	254.0"
D. Height w/ ROPS	119.0"	Inside turning radius	147.0"
E. Rolling width	68.0"	Tire overlap	0.5"

ENGINE

Cummins B3.3 80 turbocharged diesel producing 80 hp @ 2200 rpm.
Two stage air cleaner with condition indicator.

WHEELS & TIRES

7.50 X 15, 14-ply Compactor

DRIVE SYSTEM

Hydrostatic by means of a variable displacement piston pump and dual two-speed drive motors.

SPEEDS AND CONTROLS

Infinitely variable two-speed forward and reverse controlled by a single dash-mounted lever.

Low (working) 0-8 mph / High (travel) 0-16 mph

FUEL SYSTEM

40 US gallons

HYDRAULIC RESERVOIR

60 US gallons

SPRINKLER SYSTEM

110 gallon pressurized system

Position 1 - System OFF

Position 2 - System ON continuously

Position 3 - Auto ON/OFF with motion

STANDARD EQUIPMENT

Cummins water-cooled diesel engine.
14-Ply tires.

Cushioned seat with 180° rotation & side-to-side slide.

Seat belt. Horn. ROPS. Vandal cover. Back-up alarm.

Emergency engine shutdown.

Neutral safety and parking brake starter interlock.

110 gallon sprinkler system with cocoa mats

CE yellow paint

OPTIONAL EQUIPMENT

Nylon scrapers.

Heat retention shields

Michelin non-stick radial tires

Beacon light

Lighting package including:

Front working lights (2)

Rear working lights (2)

Turn signals.

ROPS canopy.

FOPS for ROPS.

*Ingram Compaction, LLC, as part of its program of continuous improvement, reserves the right to make changes in specifications and features without notice.

INGRAM

COMPACTION, LLC

2300 South Street

Racine, WI 53404

Ph: (262) 898-7338

Fax: (262) 633-5102

e-mail: info@ingramrollers.com



www.ingramrollers.com

Sold & Serviced By: